

NEW LINE



Sistemi estraibili in alluminio per mobili da cucina e bagno
Aluminium pull-out systems for kitchen and bathroom units
Systèmes extractibles en aluminium pour meubles de cuisine et de salle de bains
Sistemas extraíbles de aluminio para muebles de cocina y baño
Ausziehbare Systeme aus Aluminium für Küchen- und Badezimmermöbel

Nuovo sistema di divisione indipendente ad innesto rapido, stabile ed efficace, può essere posizionato ovunque per assicurare il contenuto dei cesti.

A new independent rapid coupling division system that is stable and efficient, and can be positioned anywhere to safeguard the contents of the baskets.

Nouveau système de division indépendante à fixation rapide, stable et efficace, peut être placé partout pour stabiliser le contenu des paniers.

Nuevo sistema de división independiente de acoplamiento rápido, estable y eficaz, que puede colocarse en cualquier espacio para asegurar el contenido de las cestas.

Das neue unabhängige Trennsystem mit Steckmechanismus ist stabil und effizient und kann überall eingesetzt werden, um den Inhalt der Körbe zu sichern.

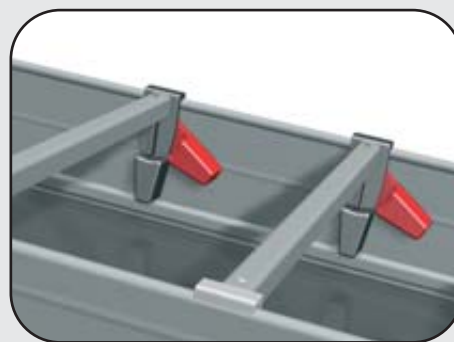

Spessori guida necessari per recuperare le varie differenze di spessore delle spalle laterali del mobile.

Runner thicknesses are necessary to compensate for any differences in thickness between the side uprights of the unit.

Cales d'épaisseur nécessaires pour rattraper les différences d'épaisseur des montants latéraux du meuble.

Suplementos de guía necesarios para ajustar las diferencias de grosor de los laterales del mueble.

Die Einlegeführungen sind notwendig, um die unterschiedliche Dicke an den Seitenteilen des Möbels auszugleichen.



Innovativo sistema di fissaggio dell'anta frontale che garantisce un rapido e preciso posizionamento della stessa.

An innovative system to fix the front panel, that guarantees fast, precise positioning.

Nouveau système de fixation de façade antérieure qui assure un positionnement rapide et précis de celle-ci.

Innovador sistema de fijación de la hoja frontal que garantiza una colocación rápida y precisa.

Das innovative Befestigungssystem der Vordertür garantiert ein schnelles, präzises Anbringen der Tür.



Lo stabilizzatore per anta permette di evitare l'oscillazione delle ante alte con ulteriore possibilità di regolazione dell'inclinazione.

The front panel stabilizer prevents the oscillation of tall doors, and the inclination can also be adjusted.

Le stabilisateur pour façade permet d'éviter l'oscillation des façades hautes, et de régler ultérieurement l'inclinaison.

El estabilizador para hoja evita la oscilación de las hojas altas con posibilidad de regular la inclinación.

Mit dem Türstabilisator kann die Schwankung der oberen Türen vermieden und die Neigung weiter reguliert werden.



Il telaio si separa dalla guida mediante un'apposita leva di sbloccaggio. Il telaio può quindi essere facilmente estratto e reintrodotta.

The frame is separated from the runner by a special release lever, so that it can be easily extracted and re-inserted.

Le châssis se sépare de la glissière au moyen d'un levier de déblocage. Il peut donc être facilement sorti et remis en place.

El bastidor se separa de la guía mediante una palanca de desbloqueo. Por lo tanto, el bastidor puede extraerse y volverse a introducir con facilidad.

Der Rahmen wird mit einem eigenen Auslösehebel von der Führung getrennt, er kann also ganz einfach herausgenommen und wieder eingesetzt werden.



Elemento scorrevole Portabottiglie ed alimenti

- Guide con autoriento ammortizzato
- Portata guide: 30 kg
- Fissaggio guide laterale

Pull-out Bottle and food holder unit

- Runners with dampened self-closing mechanism
- Runner capacity: 30 kg
- Side runner attachment

Élément coulissant Porte-bouteilles et aliments

- Glissières à retour automatique amorti
- Portée des glissières: 30 kg
- Fixation glissières latérale

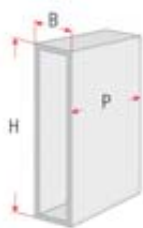

CODICE ARTICOLO/ARTICLE CODE CODE ARTICLE/CÓDIGO DEL ARTÍCULO ARTIKELNUMMER	B mm	P mm	H mm	L mm
NS3 4799B15	150	480	540	110

Elemento corredero Porta botelleros y alimentos

- Guías con retorno automático amortiguado
- Capacidad de las guías: 30 kg
- Fijación guías lateral

Auszugselement für Flaschen und Lebensmittelvorräte

- Führungsschienen mit gedämpftem Selbsteinzug
- Tragkraft der Führungen: 30 kg
- Befestigung der seitlichen Führungen



Elemento scorrevole Porta alimenti

- Guide con autoriento ammortizzato
- Portata guide: 30 Kg
- Fissaggio guide laterale

Pull-out Food holder unit

- Runners with dampened self-closing mechanism
- Runner capacity: 30 kg
- Side runner attachment

Élément coulissant Porte-aliments

- Glissières à retour automatique amorti
- Portée des glissières: 30 kg
- Fixation glissières latérale

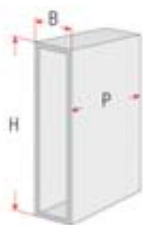

CODICE ARTICOLO/ARTICLE CODE CODE ARTICLE/CÓDIGO DEL ARTÍCULO ARTIKELNUMMER	B mm	P mm	H mm	L mm
NS3 4798B15	150	480	540	110

Elemento corredero Porta alimentos

- Guías con retorno automático amortiguado
- Capacidad de las guías: 30 kg
- Fijación guías lateral

Auszugselement für Lebensmittelvorräte

- Führungsschienen mit gedämpftem Selbsteinzug
- Tragkraft der Führungen: 30 kg
- Befestigung der seitlichen Führungen



Elemento scorrevole Portabottiglie ed alimenti

- Guide con autorientro ammortizzato
- Portata guide: 30 kg
- Fissaggio guide laterale

Pull-out Bottle and food holder unit

- Runners with dampened self-closing mechanism
- Runner capacity: 30 kg
- Side runner attachment

Élément coulissant Porte-bouteilles et aliments

- Glissières à retour automatique amorti
- Portée des glissières: 30 kg
- Fixation glissières latérale

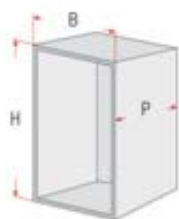

CODICE ARTICOLO/ARTICLE CODE CODE ARTICLE/CÓDIGO DEL ARTÍCULO ARTIKELNUMMER	B mm	P mm	H mm	L mm
NS3 4701B20	200	480	518	160
NS3 4701B25	250	480	518	210
NS3 4701B30	300	480	518	260
NS3 4701B35	350	480	518	310
NS3 4701B40	400	480	518	360
NS3 4701B45	450	480	518	410
NS3 4701B50	500	480	518	460

Elemento corredero Porta botelleros y alimentos

- Guías con retorno automático amortiguado
- Capacidad de las guías: 30 kg
- Fijación guías lateral

Auszugselement für Flaschen und Lebensmittelvorräte

- Führungsschienen mit gedämpftem Selbsteinzug
- Tragkraft der Führungen: 30 kg
- Befestigung der seitlichen Führungen



Elemento scorrevole Porta alimenti

- Guide con autorientro ammortizzato
- Portata guide: 30 Kg
- Fissaggio guide laterale

Pull-out Food holder unit

- Runners with dampened self-closing mechanism
- Runner capacity: 30 kg
- Side runner attachment

Élément coulissant Porte-aliments

- Glissières à retour automatique amorti
- Portée des glissières: 30 kg
- Fixation glissières latérale

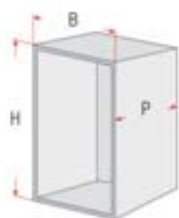

CODICE ARTICOLO/ARTICLE CODE CODE ARTICLE/CÓDIGO DEL ARTÍCULO ARTIKELNUMMER	B mm	P mm	H mm	L mm
NS3 4702B20	200	480	518	160
NS3 4702B25	250	480	518	210
NS3 4702B30	300	480	518	260
NS3 4702B35	350	480	518	310
NS3 4702B40	400	480	518	360
NS3 4702B45	450	480	518	410
NS3 4702B50	500	480	518	460

Elemento corredero Porta alimentos

- Guías con retorno automático amortiguado
- Capacidad de las guías: 30 kg
- Fijación guías lateral

Auszugselement für Lebensmittelvorräte

- Führungsschienen mit gedämpftem Selbsteinzug
- Tragkraft der Führungen: 30 kg
- Befestigung der seitlichen Führungen



Elemento scorrevole Portabottiglie ed alimenti

- Guide con autorientro ammortizzato
- Portata guide: 30 kg
- Fissaggio guide laterale

Pull-out Bottle and food holder unit

- Runners with dampened self-closing mechanism
- Runner capacity: 30 kg
- Side runner attachment

Élément coulissant Porte-bouteilles et aliments

- Glissières à retour automatique amorti
- Portée des glissières: 30 kg
- Fixation glissières latérale

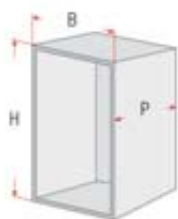

CODICE ARTICOLO/ARTICLE CODE CODE ARTICLE/CÓDIGO DEL ARTICULO ARTIKELNUMMER	B mm	P mm	H mm	L mm
NS3 4704B35	350	480	518	310
NS3 4704B40	400	480	518	360
NS3 4704B45	450	480	518	410
NS3 4704B50	500	480	518	460

Elemento corredero Porta botelleros y alimentos

- Guías con retorno automático amortiguado
- Capacidad de las guías: 30 kg
- Fijación guías lateral

Auszugselement für Flaschen und Lebensmittelvorräte

- Führungsschienen mit gedämpftem Selbsteinzug
- Tragkraft der Führungen: 30 kg
- Befestigung der seitlichen Führungen



Elemento scorrevole Cassetto basso interno

- Guide con autorientro ammortizzato
- Portata guide: 30 Kg
- Fissaggio guide laterale

Pull-out Internal low drawer

- Runners with dampened self-closing mechanism
- Runner capacity: 30 kg
- Side runner attachment

Élément coulissant Tiroir intérieur bas

- Glissières à retour automatique amorti
- Portée des glissières: 30 kg
- Fixation glissières latérale

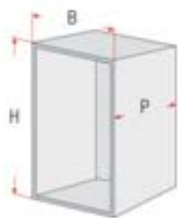

CODICE ARTICOLO/ARTICLE CODE CODE ARTICLE/CÓDIGO DEL ARTICULO ARTIKELNUMMER	B mm	P mm	H mm	L mm
NS3 4711B30	300	480	113	260
NS3 4711B35	350	480	113	310
NS3 4711B40	400	480	113	360
NS3 4711B45	450	480	113	410
NS3 4711B50	500	480	113	460
NS3 4711B60	600	480	113	560
NS3 4711B70	700	480	113	660
NS3 4711B80	800	480	113	760
NS3 4711B90	900	480	113	860
NS3 4711B100	1000	480	113	960
NS3 4711B120	1200	480	113	1160

Elemento corredero Cajón bajo interior

- Guías con retorno automático amortiguado
- Capacidad de las guías: 30 kg
- Fijación guías lateral

Auszugselement Innenschublade unten

- Führungsschienen mit gedämpftem Selbsteinzug
- Tragkraft der Führungen: 30 kg
- Befestigung der seitlichen Führungen



Elemento scorrevole Cassettoni alto interno

- Guide con autoriento ammortizzato
- Portata guide: 30 Kg
- Fissaggio guide laterale

Pull-out Internal high drawer

- Runners with dampened self-closing mechanism
- Runner capacity: 30 kg
- Side runner attachment

Élément coulissant Tiroir intérieur haut

- Glissières à retour automatique amorti
- Portée des glissières: 30 kg
- Fixation glissières latérale

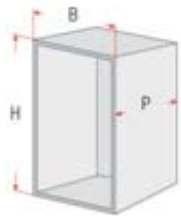

CODICE ARTICOLO/ARTICLE CODE CODE ARTICLE/CÓDIGO DEL ARTÍCULO ARTIKELNUMMER	B mm	P mm	H mm	L mm
NS3 4717B30	300	480	198	260
NS3 4717B35	350	480	198	310
NS3 4717B40	400	480	198	360
NS3 4717B45	450	480	198	410
NS3 4717B50	500	480	198	460
NS3 4717B60	600	480	198	560
NS3 4717B70	700	480	198	660
NS3 4717B80	800	480	198	760
NS3 4717B90	900	480	198	860
NS3 4717B100	1000	480	198	960
NS3 4717B120	1200	480	198	1160

Elemento corredero Cajón alto interior

- Guías con retorno automático amortiguado
- Capacidad de las guías: 30 kg
- Fijación guías lateral

Auszugselement Innenschubfach oben

- Führungsschienen mit gedämpftem Selbsteinzug
- Tragkraft der Führungen: 30 kg
- Befestigung der seitlichen Führungen



Elemento scorrevole Cassettoni alto portapentole

- Guide con autoriento ammortizzato
- Portata guide: 30 Kg
- Fissaggio guide laterale

Pull-out Internal high pan drawer

- Runners with dampened self-closing mechanism
- Runner capacity: 30 kg
- Side runner attachment

Élément coulissant Tiroir haut range casseroles

- Glissières à retour automatique amorti
- Portée des glissières: 30 kg
- Fixation glissières latérale

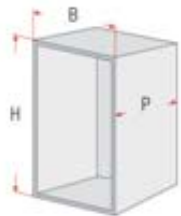

CODICE ARTICOLO/ARTICLE CODE CODE ARTICLE/CÓDIGO DEL ARTÍCULO ARTIKELNUMMER	B mm	P mm	H mm	L mm
NS3 4714B30	300	480	208	260
NS3 4714B35	350	480	208	310
NS3 4714B40	400	480	208	360
NS3 4714B45	450	480	208	410
NS3 4714B50	500	480	208	460
NS3 4714B60	600	480	208	560
NS3 4714B70	700	480	208	660
NS3 4714B80	800	480	208	760
NS3 4714B90	900	480	208	860
NS3 4714B100	1000	480	208	960
NS3 4714B120	1200	480	208	1160

Elemento corredero Cajón alto portaollas

- Guías con retorno automático amortiguado
- Capacidad de las guías: 30 kg
- Fijación guías lateral

Auszugselement Innenschubfach oben für Kochtöpfe

- Führungsschienen mit gedämpftem Selbsteinzug
- Tragkraft der Führungen: 30 kg
- Befestigung der seitlichen Führungen



- Guide con autoriento ammortizzato
- Portata guide: 50 Kg
- Fissaggio guide laterale

- Runners with dampened self-closing mechanism
- Runner capacity: 50 kg
- Side runner attachment

- Glissières à retour automatique amorti
- Portée des glissières: 50 kg
- Fixation glissières latérale

- Guías con retorno automático amortiguado
- Capacidad de las guías: 50 kg
- Fijación guías lateral

- Führungsschienen mit gedämpftem Selbsteinzug
- Tragkraft der Führungen: 50 kg
- Befestigung der seitlichen Führungen

CODICE ARTICOLO/ARTICLE CODE CODE ARTICLE/CÓDIGO DEL ARTÍCULO ARTIKELNUMMER	B mm	P mm	H mm	L mm
NS5 4715B90	900	480	208	860
NS5 4715B100	1000	480	208	960
NS5 4715B120	1200	480	208	1160

Elemento scorrevole
Porta pane o biancheria

- Guide con autoriento ammortizzato
- Portata guide: 30 kg
- Fissaggio guide laterale

Pull-out
Bread or laundry holder unit

- Runners with dampened self-closing mechanism
- Runner capacity: 30 kg
- Side runner attachment

Élément coulissant
Porte-pain ou porte-linge

- Glissières à retour automatique amorti
- Portée des glissières: 30 kg
- Fixation glissières latérale

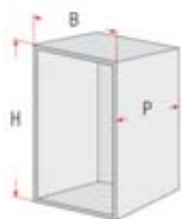

CODICE ARTICOLO/ARTICLE CODE CODE ARTICLE/CÓDIGO DEL ARTÍCULO ARTIKELNUMMER	B mm	P mm	H mm	L mm
NS3 4730B35	350	480	518	310
NS3 4730B50	500	480	518	460

Elemento corredero
Porta panera o ropa de baño

- Guías con retorno automático amortiguado
- Capacidad de las guías: 30 kg
- Fijación guías lateral

Auszugselement
als Brotkasten oder Wäschefach

- Führungsschienen mit gedämpftem Selbsteinzug
- Tragkraft der Führungen: 30 kg
- Befestigung der seitlichen Führungen

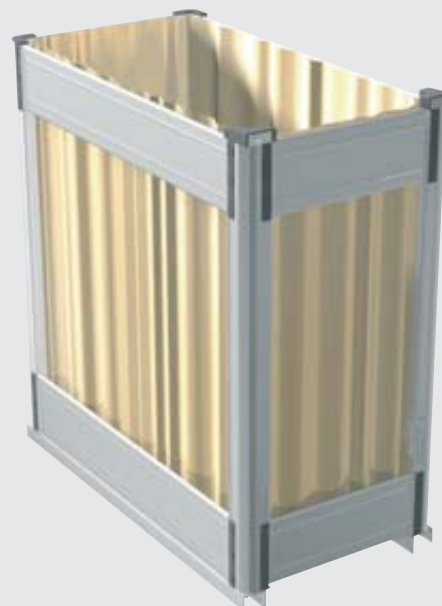

Elemento scorrevole
Porta pane, bottiglie ed alimenti

- Guide con autoriento ammortizzato
- Portata guide: 30 kg
- Fissaggio guide laterale

Pull-out
Bread, bottle and food holder unit

- Runners with dampened self-closing mechanism
- Runner capacity: 30 kg
- Side runner attachment

Élément coulissant
Porte-pain, porte-bouteilles et aliments

- Glissières à retour automatique amorti
- Portée des glissières: 30 kg
- Fixation glissières latérale

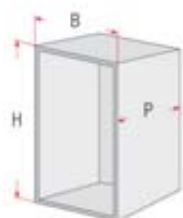

CODICE ARTICOLO/ARTICLE CODE CODE ARTICLE/CÓDIGO DEL ARTÍCULO ARTIKELNUMMER	B mm	P mm	H mm	L mm
NS3 4718B30	300	480	518	260
NS3 4718B40	400	480	518	360
NS3 4718B50	500	480	518	460

Elemento corredero
Porta panera, botellero y alimentos

- Guías con retorno automático amortiguado
- Capacidad de las guías: 30 kg
- Fijación guías lateral

Auszugselement als Brotkasten,
Flaschen- und Vorratsfach

- Führungsschienen mit gedämpftem Selbsteinzug
- Tragkraft der Führungen: 30 kg
- Befestigung der seitlichen Führungen



Elemento scorrevole

Portasecchi per rifiuti e detersivi

- Guide con autorientro ammortizzato
- Porata guide: 30 kg
- Fissaggio guide laterale

Pull-out

Unit for refuse bin and detergents

- Runners with dampened self-closing mechanism
- Runner capacity: 30 kg
- Side runner attachment

Élément coulissant

Porte-poubelles et détergents

- Glissières à retour automatique amorti
- Portée des glissières: 30 kg
- Fixation glissières latérale

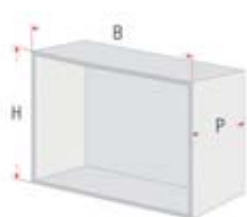

CODICE ARTICOLO/ARTICLE CODE CODE ARTICLE/CÓDIGO DEL ARTÍCULO ARTIKELNUMMER	B mm	P mm	H mm	L mm
NS3 4751B45	450	480	336	410
NS3 4751B50	500	480	336	460
NS3 4751B60	600	480	336	560

Elemento corredero

Portacubos para basura y detergentes

- Guías con retorno automático amortiguado
- Capacidad de las guías: 30 kg
- Fijación guías lateral

Auszugselement mit Abfalleimern und Putzmittelfach

- Führungsschienen mit gedämpftem Selbsteinzug
- Tragkraft der Führungen: 30 kg
- Befestigung der seitlichen Führungen

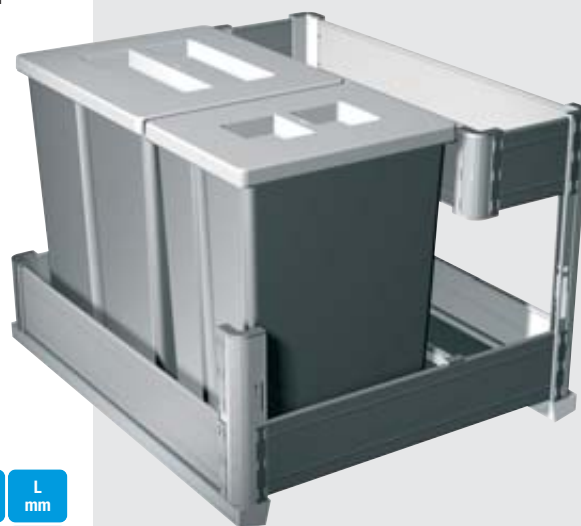

Elemento scorrevole

Portasecchi per rifiuti e detersivi

- Guide con autorientro ammortizzato
- Porata guide: 30 kg
- Fissaggio guide laterale

Pull-out

Unit for refuse bin and detergents

- Runners with dampened self-closing mechanism
- Runner capacity: 30 kg
- Side runner attachment

Élément coulissant

Porte-poubelles et détergents

- Glissières à retour automatique amorti
- Portée des glissières: 30 kg
- Fixation glissières latérale

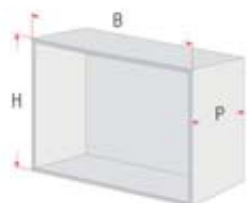

CODICE ARTICOLO/ARTICLE CODE CODE ARTICLE/CÓDIGO DEL ARTÍCULO ARTIKELNUMMER	B mm	P mm	H mm	L mm
NS3 4751B80	800	480	336	760
NS3 4751B90	900	480	336	860

Elemento corredero

Portacubos para basura y detergentes

- Guías con retorno automático amortiguado
- Capacidad de las guías: 30 kg
- Fijación guías lateral

Auszugselement mit Abfalleimern und Putzmittelfach

- Führungsschienen mit gedämpftem Selbsteinzug
- Tragkraft der Führungen: 30 kg
- Befestigung der seitlichen Führungen



Elemento scorrevole

Portasecchi per rifiuti

- Guide con autoriento ammortizzato
- Portata guide: 30 kg
- Fissaggio guide laterale

Pull-out Unit for refuse bin

- Runners with dampened self-closing mechanism
- Runner capacity: 30 kg
- Side runner attachment

Élément coulissant Porte-poubelles

- Glissières à retour automatique amorti
- Portée des glissières: 30 kg
- Fixation glissières latérale

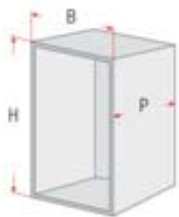

CODICE ARTICOLO/ARTICLE CODE
CODE ARTICLE/CÓDIGO DEL ARTÍCULO
ARTIKELNUMMER

NS3 4752B30

B

300

P

480

H

336

L

260

Elemento corredero

Portacubos para basura

- Guías con retorno automático amortiguado
- Capacidad de las guías: 30 kg
- Fijación guías lateral

Auszugselement mit Abfalleimern

- Führungsschienen mit gedämpftem Selbsteinzug
- Tragkraft der Führungen: 30 kg
- Befestigung der seitlichen Führungen

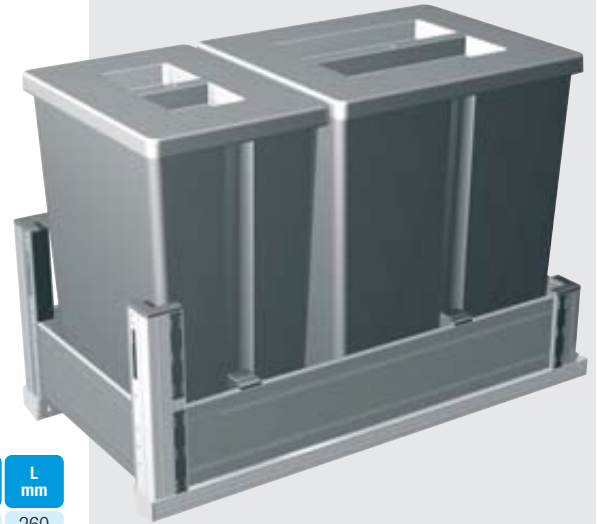

Elemento scorrevole

Portasecchi per rifiuti interno

- Guide con autoriento ammortizzato
- Portata guide: 30 kg
- Fissaggio guide laterale
SU RICHIESTA

Internal sliding bin bag-holder element

- Runners with dampened self-closing mechanism
- Runner capacity: 30 kg
- Side runner attachment
ON REQUEST

Élément coulissant

Porte poubelles internes

- Glissières à retour automatique amorti

- Portée des glissières: 30 kg

- Fixation glissières latérale
SUR COMMANDE

Elemento corredero

Para cubos de basura internos

- Guías con retorno automático amortiguado
- Capacidad de las guías: 30 kg
- Fijación guías lateral
BAJO PEDIDO

Internes Schiebeelement für Abfalleimer

- Führungsschienen mit gedämpftem Selbsteinzug
- Tragkraft der Führungen: 30 kg
- Befestigung der seitlichen Führungen
AUF ANFRAGE

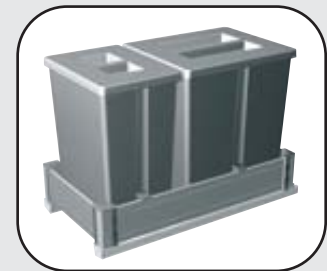

Elemento scorrevole

Portasecchi per rifiuti

- Guide con autoriento ammortizzato
- Portata guide: 30 kg
- Fissaggio guide laterale

Pull-out Unit for refuse bin

- Runners with dampened self-closing mechanism
- Runner capacity: 30 kg
- Side runner attachment

Élément coulissant Porte-poubelle

- Glissières à retour automatique amorti
- Charge glissières: 30 kg
- Fixation glissières latérale

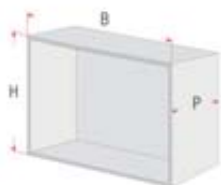

CODICE ARTICOLO/ARTICLE CODE
CODE ARTICLE/CÓDIGO DEL ARTÍCULO
ARTIKELNUMMER

NS3 4754B60

B

600

P

480

H

336

L

560

Elemento corredero

Portacubos para basura

- Guías con retorno automático amortiguado
- Capacidad de las guías: 30 kg
- Fijación guías lateral

Auszugselement mit Abfalleimern

- Führungsschienen mit gedämpftem Selbsteinzug
- Tragkraft der Führungen: 30 kg
- Befestigung der seitlichen Führungen

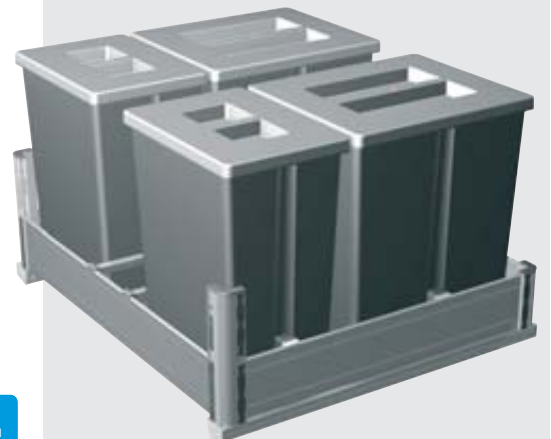

Elemento scorrevole

Portasecchi per rifiuti

- Guide con autoriento ammortizzato
- Portata guide: 30 kg
- Fissaggio guide laterale

Pull-out

Unit for refuse bin

- Runners with dampened self-closing mechanism
- Runner capacity: 30 kg
- Side runner attachment

Élément coulissant

Porte-poubelles

- Glissières à retour automatique amorti
- Portée des glissières: 30 kg
- Fixation glissières latérale

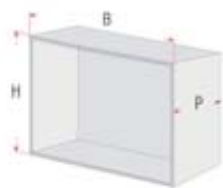

CODICE ARTICOLO/ARTICLE CODE CODE ARTICLE/CÓDIGO DEL ARTÍCULO ARTIKELNUMMER	B mm	P mm	H mm	L mm
NS3 4753B60	600	480	336	560

Elemento corredero

Portacubos para basura

- Guías con retorno automático amortiguado
- Capacidad de las guías: 30 kg
- Fijación guías lateral

Auszugselement mit Abfalleimern

- Führungsschienen mit gedämpftem Selbsteinzug
- Tragkraft der Führungen: 30 kg
- Befestigung der seitlichen Führungen



Elemento scorrevole

Portasecchi per rifiuti

- Guide con autoriento ammortizzato
- Portata guide: 30 kg
- Fissaggio guide laterale

Pull-out

Unit for refuse bin

- Runners with dampened self-closing mechanism
- Runner capacity: 30 kg
- Side runner attachment

Élément coulissant

Porte-poubelles

- Glissières à retour automatique amorti
- Portée des glissières: 30 kg
- Fixation glissières latérale

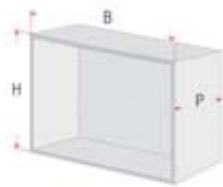

CODICE ARTICOLO/ARTICLE CODE CODE ARTICLE/CÓDIGO DEL ARTÍCULO ARTIKELNUMMER	B mm	P mm	H mm	L mm
NS3 4758B80	800	480	336	760
NS3 4758B90	900	480	336	860

Elemento corredero

Portacubos para basura

- Guías con retorno automático amortiguado
- Capacidad de las guías: 30 kg
- Fijación guías lateral

Auszugselement mit Abfalleimern

- Führungsschienen mit gedämpftem Selbsteinzug
- Tragkraft der Führungen: 30 kg
- Befestigung der seitlichen Führungen

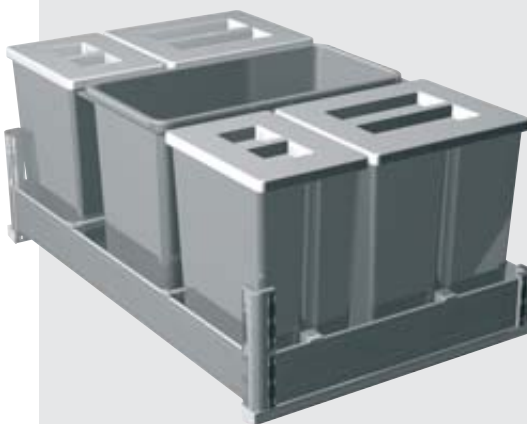

Elemento scorrevole

Portasecchi e detersivi per sottolavello

- Guide con autoriento ammortizzato
- Portata guide: 30 kg
- Fissaggio guide laterale

Pull-out under-sink refuse bin and detergent holder

- Runners with dampened self-closing mechanism
- Runner capacity: 30 kg
- Side runner attachment

Élément coulissant

Porte-poubelles et détergents sous évier

- Glissières à retour automatique amorti
- Portée des glissières: 30 kg
- Fixation glissières latérale

Elemento corredero portacubos

para basura y detergentes para debajo del fregadero

- Guías con retorno automático amortiguado
- Capacidad de las guías: 30 kg
- Fijación guías lateral

Auszugselement mit Abfalleimern und Putzmittelfach als Spülenunterschrank

- Führungsschienen mit gedämpftem Selbsteinzug
- Tragkraft der Führungen: 30 kg
- Befestigung der seitlichen Führungen



CODICE ARTICOLO/ARTICLE CODE CODE ARTICLE/CÓDIGO DEL ARTÍCULO ARTIKELNUMMER	B mm	P mm	H mm	L mm
NS3 4719B60	600	480	336	560
NS3 4719B80	800	480	336	760
NS3 4719B90	900	480	336	860
NS3 4719B100	1000	480	336	960
NS3 4719B120	1200	480	336	1160

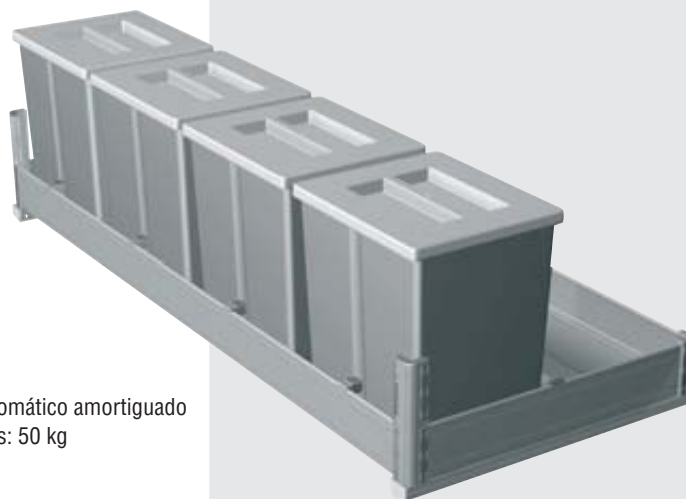
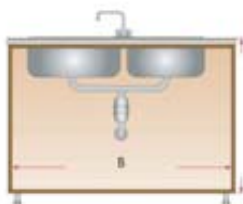

- Guide con autoriento ammortizzato
- Portata guide: 50 Kg
- Fissaggio guide laterale

- Runners with dampened self-closing mechanism
- Runner capacity: 50 kg
- Side runner attachment

- Glissières à retour automatique amorti
- Portée des glissières: 50 kg
- Fixation glissières latérale

- Guías con retorno automático amortiguado
- Capacidad de las guías: 50 kg
- Fijación guías lateral

- Führungsschienen mit gedämpftem Selbsteinzug
- Tragkraft der Führungen: 50 kg
- Befestigung der seitlichen Führungen

CODICE ARTICOLO/ARTICLE CODE CODE ARTICLE/CÓDIGO DEL ARTÍCULO ARTIKELNUMMER	B mm	P mm	H mm	L mm
NS5 4721B90	900	480	336	860
NS5 4721B100	1000	480	336	960
NS5 4721B120	1200	480	336	1160

CODICE ARTICOLO ARTICLE CODE CODE ARTICLE CÓDIGO DEL ARTÍCULO KODIERARTIKEL	N° SECCHI PER ARTICOLO NO. OF BINS PER ARTICLE N.º POUBELLES PAR ARTICLE N° CUBOS POR ARTÍCULO ANZAHL DER EIMER PRO ARTIKEL
NS3 4719B60	2
NS3 4719B80	3
NS3 4719B90	3
NS3 4719B100	4
NS3 4719B120	4
NS5 4721B90	3
NS5 4721B100	4
NS5 4721B120	4

Elemento scorrevole Portadetersivi sottovasca

- Guide con autorientro ammortizzato
- Portata guide: 30 kg
- Fissaggio guide laterale

Pull-out Under-sink detergent holder

- Runners with dampened self-closing mechanism
- Runner capacity: 30 kg
- Side runner attachment

Élément coulissant Porte-détergents sous évier

- Glissières à retour automatique amorti
- Portée des glissières: 30 kg
- Fixation glissières latérale

Elemento corredero portadetergentes para debajo del fregadero

- Guías con retorno automático amortiguado
- Capacidad de las guías: 30 kg
- Fijación guías lateral

Auszugselement als Putzmittelfach unter dem Becken

- Führungsschienen mit gedämpftem Selbsteinzug
- Tragkraft der Führungen: 30 kg
- Befestigung der seitlichen Führungen

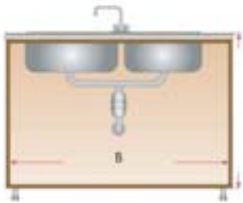

CODICE ARTICOLO/ARTICLE CODE CODE ARTICLE/CÓDIGO DEL ARTÍCULO ARTIKELNUMMER	B mm	P mm	H mm	L mm
NS3 4723B60	600	270	198	560
NS3 4723B80	800	480	198	760
NS3 4723B90	900	480	198	860
NS3 4723B100	1000	480	198	960
NS3 4723B120	1200	480	198	1160



- Guide con autorientro ammortizzato
- Portata guide: 50 Kg
- Fissaggio guide laterale

- Runners with dampened self-closing mechanism
- Runner capacity: 50 kg
- Side runner attachment

- Glissières à retour automatique amorti
- Portée des glissières: 50 kg
- Fixation glissières latérale

- Guías con retorno automático amortiguado
- Capacidad de las guías: 50 kg
- Fijación guías lateral

- Führungsschienen mit gedämpftem Selbsteinzug
- Tragkraft der Führungen: 50 kg
- Befestigung der seitlichen Führungen

CODICE ARTICOLO/ARTICLE CODE CODE ARTICLE/CÓDIGO DEL ARTÍCULO ARTIKELNUMMER	B mm	P mm	H mm	L mm
NS5 4725B90	900	480	198	860
NS5 4725B100	1000	480	198	960
NS5 4725B120	1200	480	198	1160

Elemento scorrevole porta biancheria

- Guide con autorientro ammortizzato
- Portata guide: 30 kg
- Fissaggio guide laterale

Pull-out laundry basket unit

- Runners with dampened self-closing mechanism
- Runner capacity: 30 kg
- Side runner attachment

Élément coulissant porte-linge

- Glissières à retour automatique amorti
- Portée des glissières: 30 kg
- Fixation glissières latérale

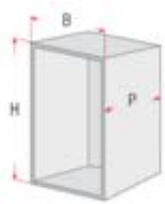

CODICE ARTICOLO/ARTICLE CODE CODE ARTICLE/CÓDIGO DEL ARTÍCULO ARTIKELNUMMER	B mm	P mm	H mm	L mm
NS3 2630E35	350	276	518	310

Elemento corredero porta ropa de baño

- Guías con retorno automático amortiguado
- Capacidad de las guías: 30 kg
- Fijación guías lateral

Auszugselement Wäschefach

- Führungsschienen mit gedämpftem Selbsteinzug
- Tragkraft der Führungen: 30 kg
- Befestigung der seitlichen Führungen



Elemento scorrevole porta oggetti

- Guide con autorientro ammortizzato
- Portata guide: 30 kg
- Fissaggio guide laterale

Pull-out objects holder unit

- Runners with dampened self-closing mechanism
- Runner capacity: 30 kg
- Side runner attachment

Élément coulissant porte-objets

- Glissières à retour automatique amorti
- Portée des glissières: 30 kg
- Fixation glissières latérale

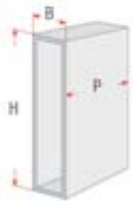

CODICE ARTICOLO/ARTICLE CODE CODE ARTICLE/CÓDIGO DEL ARTÍCULO ARTIKELNUMMER	B mm	P mm	H mm	L mm
NS3 2699E15	150	276	540	110

Elemento corredero porta objetos

- Guías con retorno automático amortiguado
- Capacidad de las guías: 30 kg
- Fijación guías lateral

Auszugselement Ablagefach

- Führungsschienen mit gedämpftem Selbsteinzug
- Tragkraft der Führungen: 30 kg
- Befestigung der seitlichen Führungen



Elemento scorrevole porta oggetti

- Guide con autorientro ammortizzato
- Portata guide: 30 kg
- Fissaggio guide laterale

Pull-out objects holder unit

- Runners with dampened self-closing mechanism
- Runner capacity: 30 kg
- Side runner attachment

Élément coulissant porte-objets

- Glissières à retour automatique amorti
- Portée des glissières: 30 kg
- Fixation glissières latérale

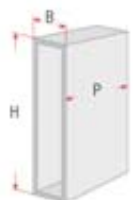

CODICE ARTICOLO/ARTICLE CODE CODE ARTICLE/CÓDIGO DEL ARTÍCULO ARTIKELNUMMER	B mm	P mm	H mm	L mm
NS3 2698E15	150	276	540	110

Elemento corredero porta objetos

- Guías con retorno automático amortiguado
- Capacidad de las guías: 30 kg
- Fijación guías lateral

Auszugselement Ablagefach

- Führungsschienen mit gedämpftem Selbsteinzug
- Tragkraft der Führungen: 30 kg
- Befestigung der seitlichen Führungen



Colonnina

- Guide con autorientro ammortizzato
- Portata guide: 50 kg
- Fissaggio guide laterale

Column

- Runners with dampened self-closing mechanism
- Runner capacity: 50 kg
- Side runner attachment

Colonne

- Glissières à retour automatique amorti
- Portée des glissières: 50 kg
- Fixation glissières latérale

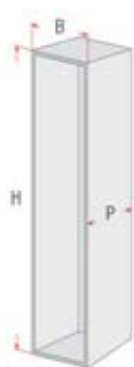

CODICE ARTICOLO/ARTICLE CODE CODE ARTICLE/CÓDIGO DEL ARTÍCULO ARTIKELNUMMER	B mm	P mm	H mm	L mm
NS5 4770B20	200	480	1294	160
NS5 4770B25	250	480	1294	210
NS5 4770B30	300	480	1294	260
NS5 4770B35	350	480	1294	310
NS5 4770B40	400	480	1294	360

Larguero

- Guías con retorno automático amortiguado
- Capacidad de las guías: 50 kg
- Fijación guías lateral

Säule

- Führungsschienen mit gedämpftem Selbsteinzug
- Tragkraft der Führungen: 50 kg
- Befestigung der seitlichen Führungen



Colonnina

- Guide con autorientro ammortizzato
- Portata guide: 50 kg
- Fissaggio guide laterale

Column

- Runners with dampened self-closing mechanism
- Runner capacity: 50 kg
- Side runner attachment

Colonne

- Glissières à retour automatique amorti
- Portée des glissières: 50 kg
- Fixation glissières latérale

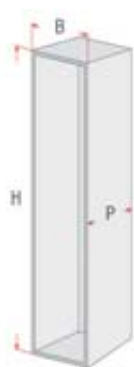

CODICE ARTICOLO/ARTICLE CODE CODE ARTICLE/CÓDIGO DEL ARTÍCULO ARTIKELNUMMER	B mm	P mm	H mm	L mm
NS5 4769B20	200	480	900	160
NS5 4769B25	250	480	900	210
NS5 4769B30	300	480	900	260
NS5 4769B35	350	480	900	310
NS5 4769B40	400	480	900	360

Larguero

- Guías con retorno automático amortiguado
- Capacidad de las guías: 50 kg
- Fijación guías lateral

Säule

- Führungsschienen mit gedämpftem Selbsteinzug
- Tragkraft der Führungen: 50 kg
- Befestigung der seitlichen Führungen

