

# CHECKMATE

Elementi scorrevoli  
per basi ad angolo

Sliding elements  
for corner base units

Éléments coulissants  
pour armoires de base  
angulaires

Elementos deslizantes  
para bases en ángulo

Schiebeelemente  
für Ecksockel



Meccanismo con il solo fissaggio al basamento del mobile

Mechanism with attachment only to base of furniture unit

Mécanisme seulement avec la fixation à la base du meuble

Mecanismo con una sola fijación a la base del mueble

Mechanismus nur mit Befestigung am Sockel des Möbelstücks

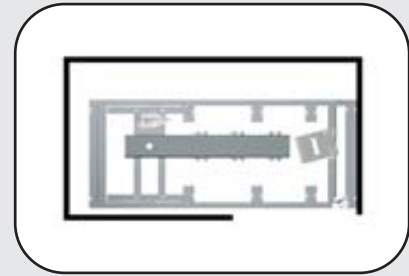

L'unico elemento che sfrutta tutta la capacità del vano

The only element that exploits the entire capacity of the compartment

Le seul élément qui permet d'utiliser tout le volume du compartiment

El único elemento que aprovecha toda la capacidad del espacio

Das einzige Element, mit dem das gesamte zur Verfügung stehende Volumen ausgenutzt wird

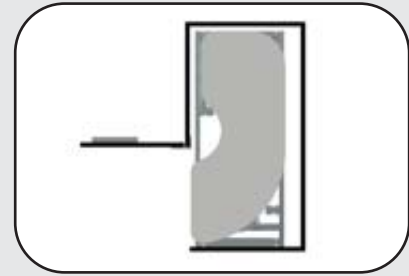

Aggancio rapido del monoblocco a ripiani

Rapid coupling of shelf unit

Accrochage rapide du monobloc à tablettes

Enganche rápido del monobloque con estantes

Einhaken des Monoblocks mit Böden

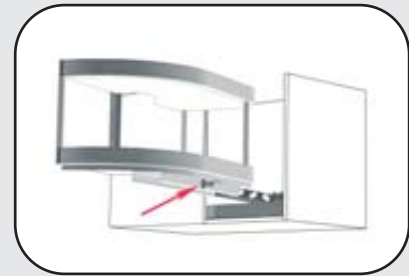

Elemento con fissaggio dell'anta frontale

Element with attachment of front flap

Élément avec fixation de la porte en façade

Elemento con fijación de la hoja frontal

Element mit Befestigung der Fronttür

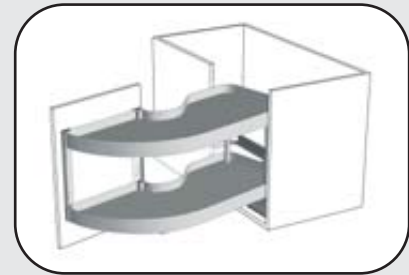

Innesto al meccanismo del monoblocco a ripiani

Engagement of shelf unit with mechanism

Engagement sur le mécanisme du monobloc à tablettes

Acoplamiento al mecanismo del monobloque con estantes

Eingriff in den Mechanismus des Monoblocks mit Böden



Elemento interno con anta a cerniera

Internal element with hinged flap

Élément interne avec porte à charnières

Elemento interno con hoja de bisagra

Internes Element mit Scharnirtür



## Elemento scorrevole per basi ad angolo Destro con fissaggio per anta frontale

- Guide con autoriento ammortizzato
- Portata guide: 50 kg
- Fissaggio guide alla base del mobile

## Sliding element for right corner bases with attachment for front flap

- Runners with dampened self-closing mechanism
- Runner capacity: 50 kg
- Runner attachment to base of unit

## Élément coulissant pour armoires inférieures angulaire droit avec fixation pour porte en façade

- Glissières à retour automatique amorti
- Portée des glissières: 50 kg
- Fixation des glissières à la base du meuble

## Elemento deslizante para bases en ángulo derecho con fijación para la hoja frontal

- Guías con retorno automático amortiguado
- Capacidad de las guías: 50 kg
- Fijación de las guías a la base del mueble

## Schiebeelement für Ecksockel rechts mit Befestigung für Fronttür

- Führungsschienen mit gedämpftem Selbsteinzug
- Tragkraft der Führungen: 50 kg
- Befestigung der Führungen am Sockel des Möbelstücks

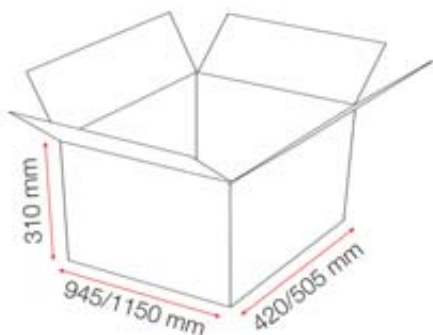

CODICE ARTICOLO ARTICLE CODE/CODE ARTICLE CÓDIGO DEL ARTÍCULO ARTIKELNUMMER	L mm	P mm	H mm	ANGOLO / CORNER ANGLE / ÁNGULO ECKE	ANTA FRONTALE FRONT FLAP / PORTE EN FAÇADE / HOJA FRONTAL / FRONTTÜR
V100 DR 45	940	415	505	DESTRO / RIGHT / DROIT DERECHO / RECHTS	45/55 cm
V120 DR 60	1146	498	505	DESTRO / RIGHT / DROIT DERECHO / RECHTS	60/70 cm

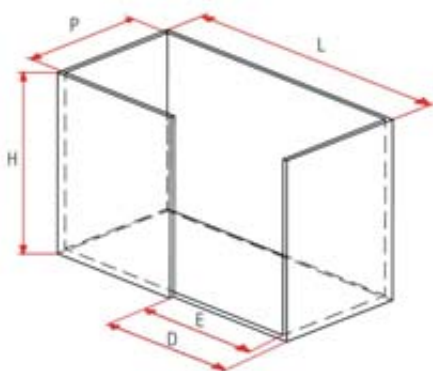

DIMENSIONI ED INGOMBRI VANO  
MEASUREMENTS AND VOLUME  
OF COMPARTMENT  
DIMENSIONS ET ENCOMBREMENT  
COMPARTIMENT  
DIMENSIONES Y CAPACIDAD  
DEL ESPACIO  
ABMESSUNGEN UND RAUMBEDARF

Cod. art. V100 DR 45	Cod. art. V120 DR 60
L= ≥ 1000 mm	L= ≥ 1200 mm
P= ≥ 500 mm	P= ≥ 500 mm
E= ≥ 430 mm	E= ≥ 580 mm
H= ≥ 600 mm	H= ≥ 600 mm
D= 450/550 mm	D= 600/700 mm

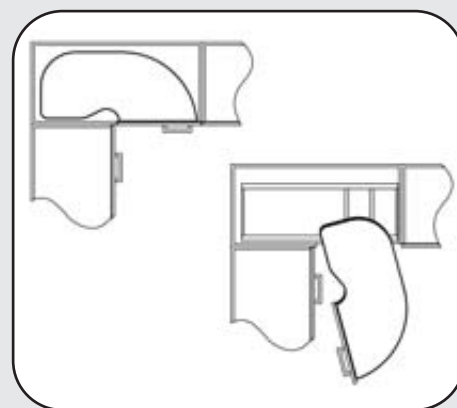

## Elemento scorrevole per basi ad angolo Sinistro con fissaggio per anta frontale

- Guide con autoriento ammortizzato
- Portata guide: 50 kg
- Fissaggio guide alla base del mobile

## Sliding element for left corner bases with attachment for front flap

- Runners with dampened self-closing mechanism
- Runner capacity: 50 kg
- Runner attachment to base of unit

## Élément coulissant pour armoires inférieures angulaire gauche avec fixation pour porte en façade

- Glissières à retour automatique amorti
- Portée des glissières: 50 kg
- Fixation des glissières à la base du meuble

## Elemento deslizante para bases en ángulo izquierdo con fijación para la hoja frontal

- Guías con retorno automático amortiguado
- Capacidad de las guías: 50 kg
- Fijación de las guías a la base del mueble

## Schiebeelement für Ecksockel links mit Befestigung für Fronttür

- Führungsschienen mit gedämpftem Selbsteinzug
- Tragkraft der Führungen: 50 kg
- Befestigung der Führungen am Sockel des Möbelstücks

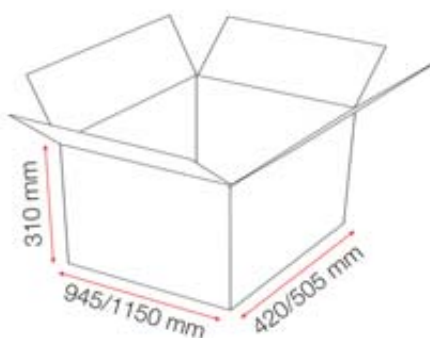

CODICE ARTICOLO ARTICLE CODE/CODE ARTICLE CÓDIGO DEL ARTÍCULO ARTIKELNUMMER	L mm	P mm	H mm	ANGOLO/CORNER ANGLE/ANGULO ECKE	ANTA FRONTALE FRONT FLAP/PORTE EN FAÇADE/HOJA FRONTAL/Fronttür
V100 SL 45	940	415	505	SINISTRO/LEFT/GAUCHE IZQUIERDO/LINKS	45/55 cm
V120 SL 60	1146	498	505	SINISTRO/LEFT/GAUCHE IZQUIERDO/LINKS	60/70 cm

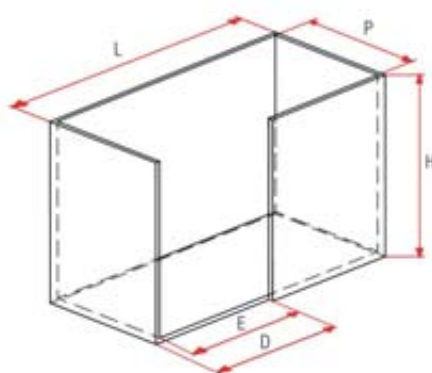

DIMENSIONI ED INGOMBRI VANO  
MEASUREMENTS AND VOLUME  
OF COMPARTMENT  
DIMENSIONS ET ENCOMBREMMENT  
COMPARTIMENT  
DIMENSIONES Y CAPACIDAD  
DEL ESPACIO  
ABMESSUNGEN UND RAUMBEDARF

Cod. art. V100 SL 45	Cod. art. V120 SL 60
L= ≥ 1000 mm	L= ≥ 1200 mm
P= ≥ 500 mm	P= ≥ 500 mm
E= ≥ 430 mm	E= ≥ 580 mm
H= ≥ 600 mm	H= ≥ 600 mm
D= 450/550 mm	D= 600/700 mm

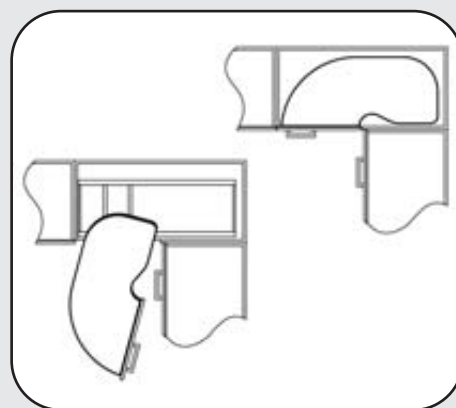

## Elemento scorrevole per basi ad angolo Destro per ante a battente

- Guide con autorientamento ammortizzato
- Portata guide: 50 kg
- Fissaggio guide alla base del mobile

## Sliding element for right corner bases for flap doors

- Runners with dampened self-closing mechanism
- Runner capacity: 50 kg
- Runner attachment to base of unit

## Élément coulissant pour armoires inférieures angulaire droit pour portes à battant

- Glissières à retour automatique amorti
- Portée des glissières: 50 kg
- Fixation des glissières à la base du meuble

## Elemento deslizante para bases en ángulo derecho para puertas de hoja

- Guías con retorno automático amortiguado
- Capacidad de las guías: 50 kg
- Fijación de las guías a la base del mueble

## Schiebeelement für Ecksockel rechts für Flügeltüren

- Führungsschienen mit gedämpftem Selbsteinzug
- Tragkraft der Führungen: 50 kg
- Befestigung der Führungen am Sockel des Möbelstücks

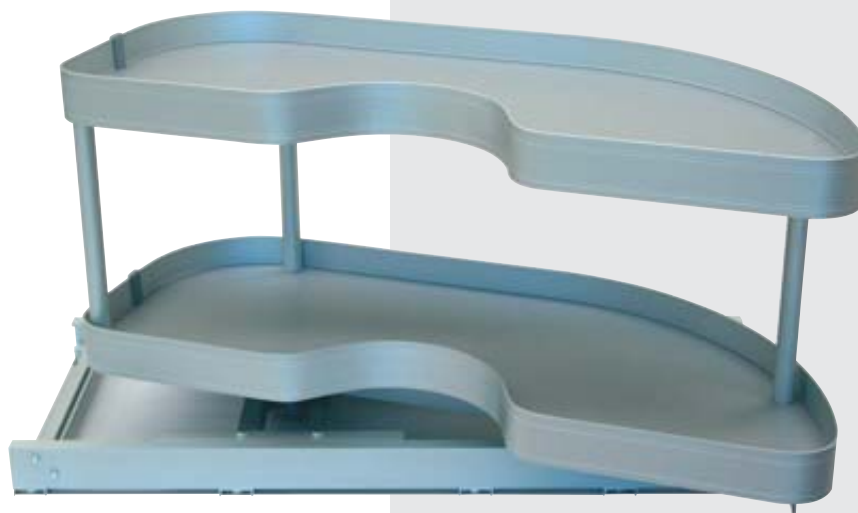
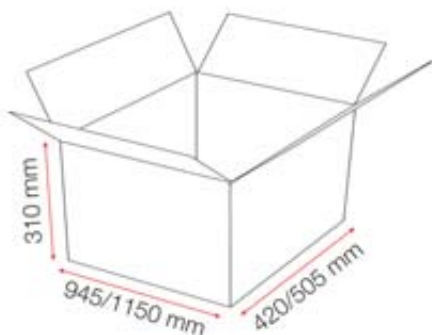

CODICE ARTICOLO ARTICLE CODE/CODE ARTICLE CÓDIGO DEL ARTÍCULO ARTIKELNUMMER	L mm	P mm	H mm	ANGOLO / CORNER ANGLE / ÁNGULO ECKE
V101 DR 41	940	415	505	DESTRO / RIGHT / DROIT DERECHO / RECHTS
V121 DR 56	1146	498	505	DESTRO / RIGHT / DROIT DERECHO / RECHTS

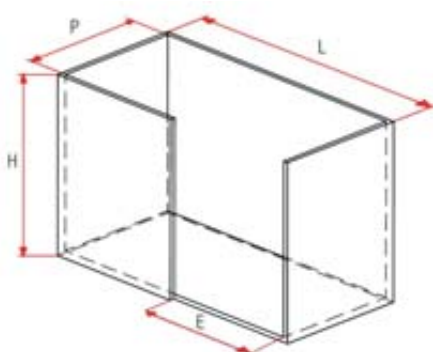

DIMENSIONI ED INGOMBRI VANO  
MEASUREMENTS AND VOLUME  
OF COMPARTMENT  
DIMENSIONS ET ENCOMBREMENT  
COMPARTIMENT  
DIMENSIONES Y CAPACIDAD  
DEL ESPACIO  
ABMESSUNGEN UND RAUMBEDARF

Cod. art. V101 DR 41	Cod. art. V121 DR 56
L= ≥ 1000 mm	L= ≥ 1200 mm
P= ≥ 500 mm	P= ≥ 500 mm
E= ≥ 430 mm	E= ≥ 580 mm
H= ≥ 600 mm	H= ≥ 600 mm

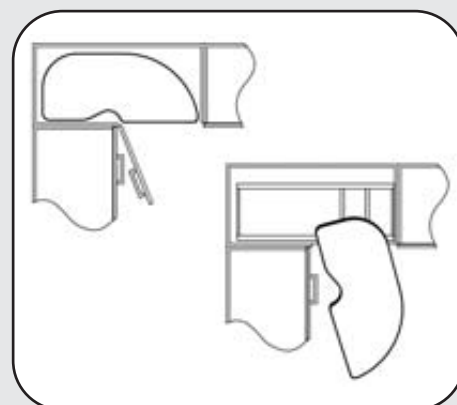

## Elemento scorrevole per basi ad angolo Sinistro per ante a battente

- Guide con autoriento ammortizzato
- Portata guide: 50 kg
- Fissaggio guide alla base del mobile

## Sliding element for left corner bases for flap doors

- Runners with dampened self-closing mechanism
- Runner capacity: 50 kg
- Runner attachment to base of unit

## Élément coulissant pour armoires inférieures angulaire gauche pour portes à battant

- Glissières à retour automatique amorti
- Portée des glissières: 50 kg
- Fixation des glissières à la base du meuble

## Elemento deslizante para bases en ángulo izquierdo para puertas de hoja

- Guías con retorno automático amortiguado
- Capacidad de las guías: 50 kg
- Fijación de las guías a la base del mueble

## Schiebeelement für Ecksockel links für Flügeltüre

- Führungsschienen mit gedämpftem Selbsteinzug
- Tragkraft der Führungen: 50 kg
- Befestigung der Führungen am Sockel des Möbelstücks

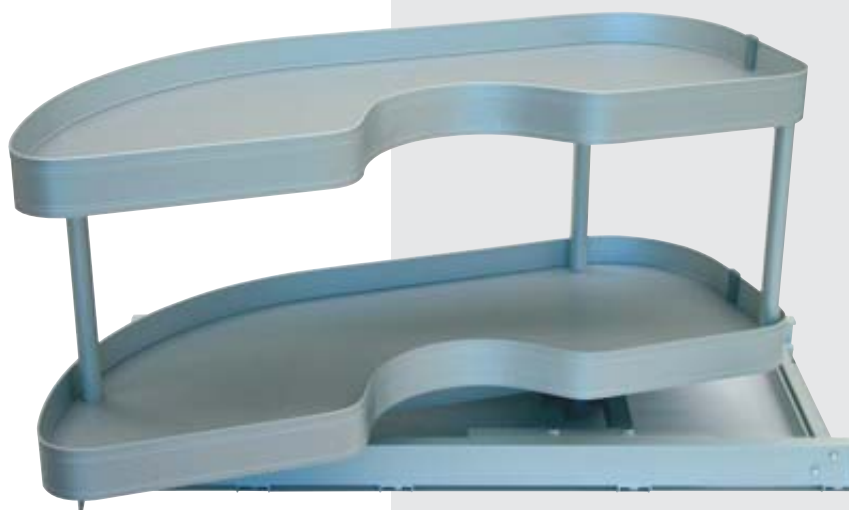
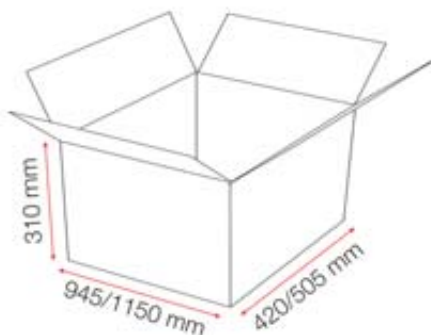

CODICE ARTICOLO ARTICLE CODE/CODE ARTICLE CÓDIGO DEL ARTÍCULO ARTIKELNUMMER	L mm	P mm	H mm	ANGOLO / CORNER ANGLE / ÁNGULO ECKE
V101 SL 41	940	415	505	SINISTRO/LEFT/GAUCHE IZQUIERDO/LINKS
V121 SL 56	1146	498	505	SINISTRO/LEFT/GAUCHE IZQUIERDO/LINKS

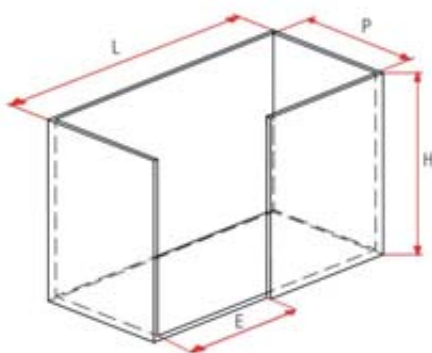

DIMENSIONI ED INGOMBRI VANO  
MEASUREMENTS AND VOLUME  
OF COMPARTMENT  
DIMENSIONS ET ENCOMBREMENT  
COMPARTIMENT  
DIMENSIONES Y CAPACIDAD  
DEL ESPACIO  
ABMESSUNGEN UND RAUMBEDARF

Cod. art. V101 SL 41	Cod. art. V121 SL 56
L= ≥ 1000 mm	L= ≥ 1200 mm
P= ≥ 500 mm	P= ≥ 500 mm
E= ≥ 430 mm	E= ≥ 580 mm
H= ≥ 600 mm	H= ≥ 600 mm

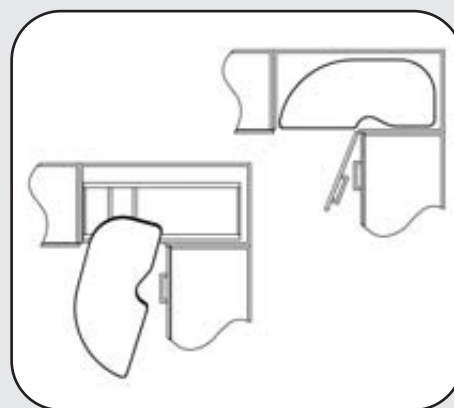

## Elemento scorrevole per basi ad angolo Destro a 3 ripiani per ante a battente

- Guide con autorientamento ammortizzato
- Portata guide: 50 kg
- Fissaggio guide alla base del mobile

## Sliding element for right corner bases with 3 shelves for flap doors

- Runners with dampened self-closing mechanism
- Runner capacity: 50 kg
- Runner attachment to base of unit

## Élément coulissant pour armoires inférieures angulaire droit à 3 tablettes pour portes à battant

- Glissières à retour automatique amorti
- Portée des glissières: 50 kg
- Fixation des glissières à la base du meuble

## Elemento deslizante para bases en ángulo derecho con tres estantes para puertas de hoja

- Guías con retorno automático amortiguado
- Capacidad de las guías: 50 kg
- Fijación de las guías a la base del mueble

## Schiebeelement für Ecksockel rechts mit 3 Einlegeböden für Flügeltüren

- Führungsschienen mit gedämpftem Selbsteinzug
- Tragkraft der Führungen: 50 kg
- Befestigung der Führungen am Sockel des Möbelstücks

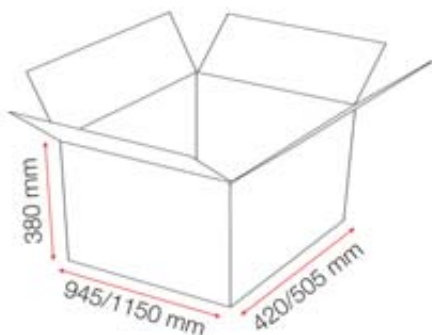

CODICE ARTICOLO ARTICLE CODE/CODE ARTICLE CÓDIGO DEL ARTÍCULO ARTIKELNUMMER	L mm	P mm	H mm	ANGOLO / CORNER ANGLE / ÁNGULO ECKE
V103 DR 41	940	415	820	DESTRO/RIGHT/DROIT DERECHO/RECHTS
V123 DR 56	1146	498	820	DESTRO/RIGHT/DROIT DERECHO/RECHTS

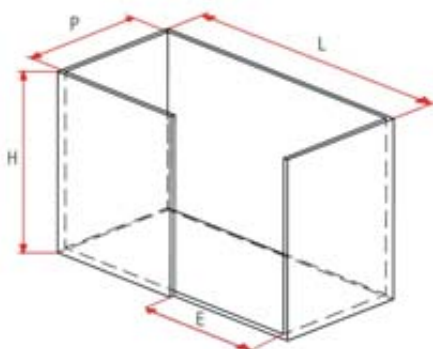

DIMENSIONI ED INGOMBRI VANO  
MEASUREMENTS AND VOLUME  
OF COMPARTMENT  
DIMENSIONS ET ENCOMBREMENT  
COMPARTIMENT  
DIMENSIONES Y CAPACIDAD  
DEL ESPACIO  
ABMESSUNGEN UND RAUMBEDARF

Cod. art. V103 DR 41	Cod. art. V123 DR 56
L= ≥ 1000 mm	L= ≥ 1200 mm
P= ≥ 500 mm	P= ≥ 500 mm
E= ≥ 430 mm	E= ≥ 580 mm
H= ≥ 1000 mm	H= ≥ 1000 mm

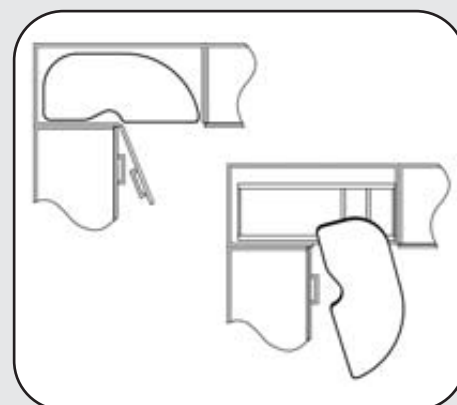

## Elemento scorrevole per basi ad angolo Sinistro a 3 ripiani per ante a battente

- Guide con autorientro ammortizzato
- Portata guide: 50 kg
- Fissaggio guide alla base del mobile

## Sliding element for left corner bases with 3 shelves for flap doors

- Runners with dampened self-closing mechanism
- Runner capacity: 50 kg
- Runner attachment to base of unit

## Élément coulissant pour armoires inférieures angulaire gauche à 3 tablettes pour portes à battant

- Glissières à retour automatique amorti
- Portée des glissières: 50 kg
- Fixation des glissières à la base du meuble

## Elemento deslizante para bases en ángulo izquierdo con tres estantes para puertas de hoja

- Guías con retorno automático amortiguado
- Capacidad de las guías: 50 kg
- Fijación de las guías a la base del mueble

## Schiebeelement für Ecksockel links mit 3 Einlegeböden für Flügeltüren

- Führungsschienen mit gedämpftem Selbsteinzug
- Tragkraft der Führungen: 50 kg
- Befestigung der Führungen am Sockel des Möbelstücks

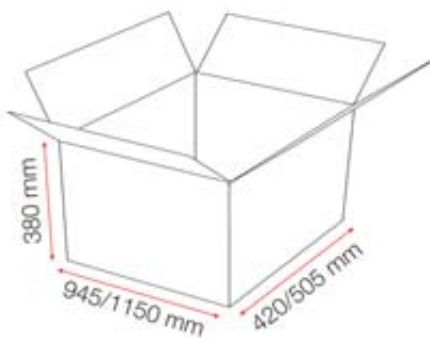

CODICE ARTICOLO ARTICLE CODE/CODE ARTICLE CÓDIGO DEL ARTÍCULO ARTIKELNUMMER	L mm	P mm	H mm	ANGOLO / CORNER ANGLE / ANGULO ECKE
V103 SL 41	940	415	820	SINISTRO/LEFT/GAUCHE IZQUIERDO/LINKS
V123 SL 56	1146	498	820	SINISTRO/LEFT/GAUCHE IZQUIERDO/LINKS

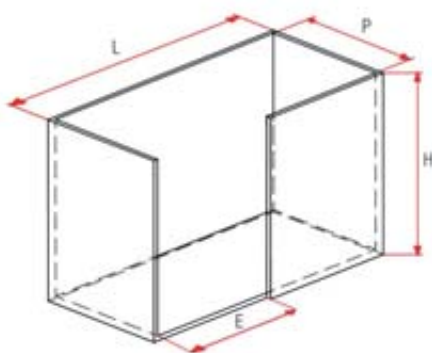

DIMENSIONI ED INGOMBRI VANO  
MEASUREMENTS AND VOLUME  
OF COMPARTMENT  
DIMENSIONS ET ENCROBREMMENT  
COMPARTIMENT  
DIMENSIONES Y CAPACIDAD  
DEL ESPACIO  
ABMESSUNGEN UND RAUMBEDARF

Cod. art. V103 SL 41	Cod. art. V123 SL 56
L = ≥ 1000 mm	L = ≥ 1200 mm
P = ≥ 500 mm	P = ≥ 500 mm
E = ≥ 430 mm	E = ≥ 580 mm
H = ≥ 1000 mm	H = ≥ 1000 mm

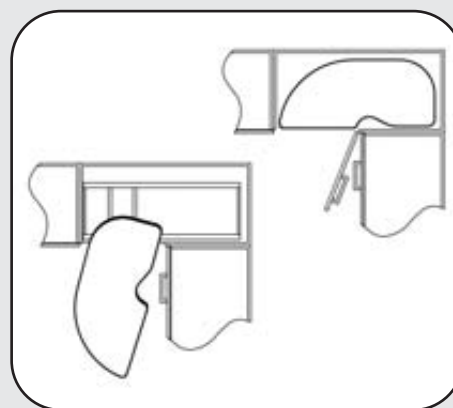



## Elemento scorrevole per basi ad angolo Destro a 4 ripiani per ante a battente

- Guide con autoriento ammortizzato
- Portata guide: 50 kg
- Fissaggio guide alla base del mobile

## Sliding element for right corner bases with 4 shelves for flap doors

- Runners with dampened self-closing mechanism
- Runner capacity: 50 kg
- Runner attachment to base of unit

## Élément coulissant pour armoires inférieures angulaire droit à 4 tablettes pour portes à battant

- Glissières à retour automatique amorti
- Portée des glissières: 50 kg
- Fixation des glissières à la base du meuble

## Elemento deslizante para bases en ángulo derecho con cuatro estantes para puertas de hoja

- Guías con retorno automático amortiguado
- Capacidad de las guías: 50 kg
- Fijación de las guías a la base del mueble

## Schiebeelement für Ecksockel rechts mit 4 Einlegeböden für Flügeltüren

- Führungsschienen mit gedämpftem Selbsteinzug
- Tragkraft der Führungen: 50 kg
- Befestigung der Führungen am Sockel des Möbelstücks

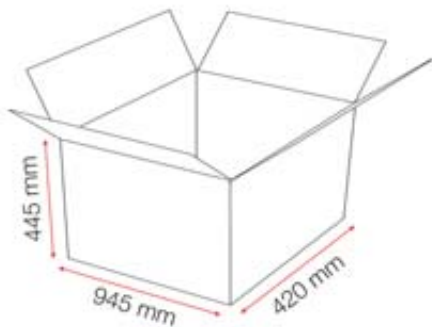

CODICE ARTICOLO ARTICLE CODE/CODE ARTICLE CÓDIGO DEL ARTÍCULO ARTIKELNUMMER	L mm	P mm	H mm	ANGOLO / CORNER ANGLE / ÁNGULO ECKE
V104 DR 41	940	415	1140	DESTRO / RIGHT / DROIT DERECHO / RECHTS

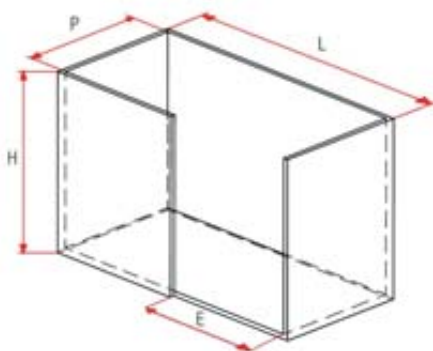

DIMENSIONI ED INGOMBRI VANO  
MEASUREMENTS AND VOLUME  
OF COMPARTMENT  
DIMENSIONS ET ENCOMBREMENT  
COMPARTIMENT  
DIMENSIONES Y CAPACIDAD  
DEL ESPACIO  
ABMESSUNGEN UND RAUMBEDARF

Cod. art. V104 DR 41
L= ≥ 1000 mm
P= ≥ 500 mm
E= ≥ 430 mm
H= ≥ 1400 mm

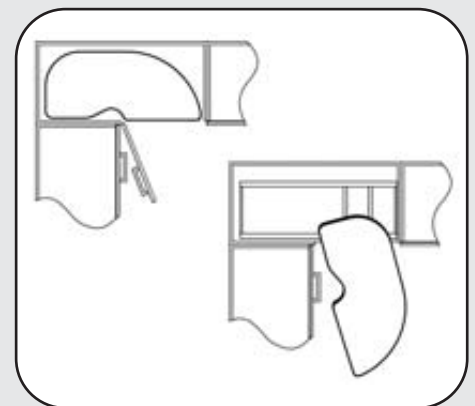

## Elemento scorrevole per basi ad angolo Sinistro a 4 ripiani per ante a battente

- Guide con autoriento ammortizzato
- Portata guide: 50 kg
- Fissaggio guide alla base del mobile

## Sliding element for left corner bases with 4 shelves for flap doors

- Runners with dampened self-closing mechanism
- Runner capacity: 50 kg
- Runner attachment to base of unit

## Élément coulissant pour armoires inférieures angulaire gauche à 4 tablettes pour portes à battant

- Glissières à retour automatique amorti
- Portée des glissières: 50 kg
- Fixation des glissières à la base du meuble

## Elemento deslizante para bases en ángulo izquierdo con cuatro estantes para puertas de hoja

- Guías con retorno automático amortiguado
- Capacidad de las guías: 50 kg
- Fijación de las guías a la base del mueble

## Schiebeelement für Ecksockel links mit 4 Einlegeböden für Flügeltüren

- Führungsschienen mit gedämpftem Selbsteinzug
- Tragkraft der Führungen: 50 kg
- Befestigung der Führungen am Sockel des Möbelstücks

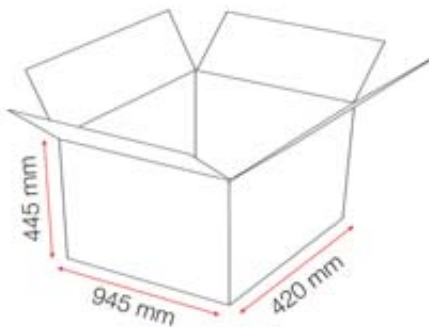

CODICE ARTICOLO ARTICLE CODE/CODE ARTICLE CÓDIGO DEL ARTÍCULO ARTIKELNUMMER	L mm	P mm	H mm	ANGOLO / CORNER ANGLE / ANGULO ECKE
V104 SL 41	940	415	1140	SINISTRO/LEFT/GAUCHE IZQUIERDO/LINKS

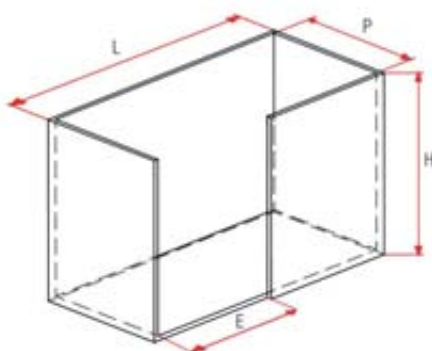

DIMENSIONI ED INGOMBRI VANO  
MEASUREMENTS AND VOLUME  
OF COMPARTMENT  
DIMENSIONS ET ENCOMBREMENT  
COMPARTIMENT  
DIMENSIONES Y CAPACIDAD  
DEL ESPACIO  
ABMESSUNGEN UND RAUMBEDARF

- Cod. art.  
V104 SL 41**
- L= ≥ 1000 mm
  - P= ≥ 500 mm
  - E= ≥ 430 mm
  - H= ≥ 1400 mm

